

## Application Note AN108

### *Comparing Grow Lights*

---

## ***High-Wattage Special-Purpose Lamps***

***A Comparison of Halogen, Compact-Fluorescent (CFL), High Pressure Sodium (HPS) and LED Lamps In High-Performance Photographic and Grow-light Applications...***

### ***Some Things Many Users Do Not Know***

Most professional photographers are familiar with terms like Lumens, Lumens-Per-Watt, Lux, Foot-Candles, etc. Likewise, they are aware of the transition from incandescent and halogen (which is just a slightly more efficient version of regular incandescent) toward Compact Fluorescent Lamps (CFL) and LEDs. They also know that reflectors can significantly increase the amount of light directed toward a subject or scene.

Similarly, those involved non-photographic markets, such as indoor growing, know that High-Pressure-Sodium lamps (HPS) are still dominant in many global indoor-farming markets because of low cost and seeming very high efficiency.

What many users do not know is that things are not always as they seem--- or as promoted. Let's walk through some of these often-misunderstood areas.

What is the meaning of the Lumens rating of a photographic light source...or the PPF rating of a grow-light ? (They both mean "almost" the same thing but in different language suited to the way used. Let's talk about the four most common light sources which today have a "lumen" or PPF Specifications:

1. Incandescent lamp (including halogen type).
2. CFL lamp
3. HID lamps (Including High Pressure Sodium and Metal Halide Types)
4. LED chip. The chip, as purchased, is still not usable to a photographer, It must be put into an additional component assembly by another company or assembly line before it can be called a screw-in "lamp".

In almost all cases, the manufacturers test samples of the light source (lamp or chip) in what is called an “integrating sphere” Figure 1 , a sophisticated test apparatus where virtually 100% of emitted light from possible directions is collected and measured.

Typically, lamp samples, to establish a spec, are tested one time in the integrating sphere. However, LED chips are tested by the chip maker in the sphere but there is a second test when in final lamp form, by the lamp maker /seller. The LED lamp will always show a 25-30% lower lumen rating than a bare chip component because of losses in all the other thermal, electronic and optical parts of the lamp. Many LED lamp makers falsely promote high lumen numbers by using specs of the bare led chip data sheet itself instead of for assembled lamp.

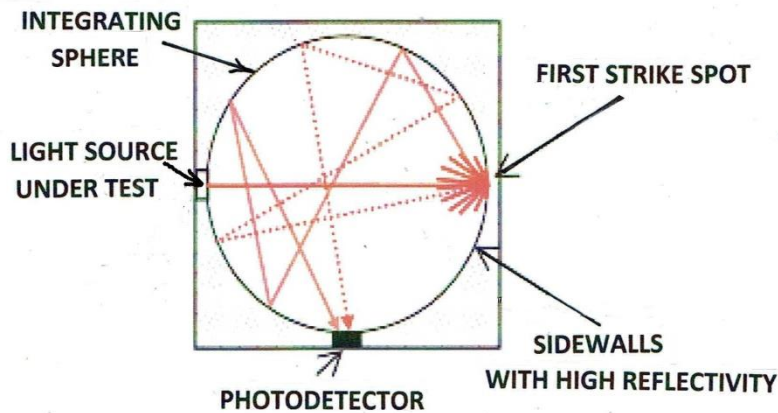

Figure 1 Integrating

## Sphere

In the Figure 1 diagram, an “infinite” number of light rays bounce off all the internal sphere reflective surfaces so that almost all the emitted is light collected and measured at one point. This is an ideal arrangement. In actual practice, it is impossible get all of the emitted light to a specific target.

All manufacturers of incandescent, fluorescent, LED or HID lamps know that the only way to accurately know the emitted lumens is to measure in this type of integrating sphere or a related instrument, called a “goniometer”, typically used for large complete lighting fixtures which might have sizes or shapes which can be properly tested in the sphere..

With an incandescent lamp, light comes off the filament in virtually a 360 degree-spherical pattern (Figure 2), so only a tiny fraction reaches any point away from the lamps,

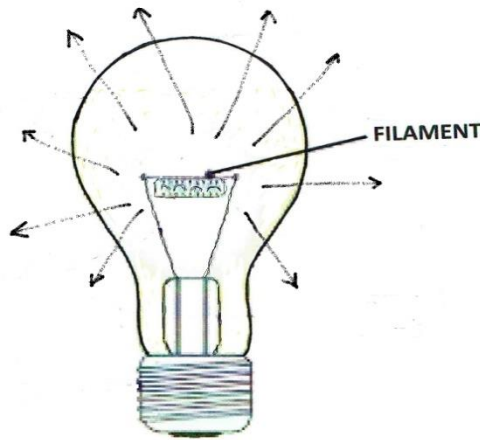

**Figure 2**  
**Incandescent/Halogen**  
**Light-Emission Pattern**

Consequently, the lumen rating of a halogen lamp is almost useless to a photographer unless he can collect most of the light heading out in every direction and redirect it forward with a focusing reflector. How much of light he can collect and how much ends up at the target depends on the size, shape and efficiency of the reflector. The results can vary dramatically.

Simple experiments will quick show that a tiny battery operated LED flashlight, operating with a one-watt LED, with a narrow beam angle lens can put much more light onto a small object than a 100-watt bare incandescent light bulb—both 10 feet (about 3 meters) away.

Automobile-headlight designers have long known that precision lenses and reflectors can allow 40-50 watt lamps to project powerful beams a long distance onto the road ahead

Virtually all professional photographers, for many years before CFL's were available, have known what combinations of incandescent/halogen lamps and large reflectors would give them appropriate light levels,

**Figure 3** Compact Fluorescent Lamp (CFL)

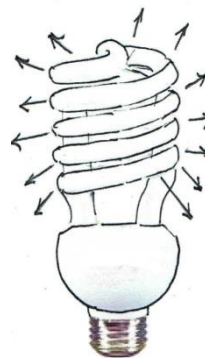

CFLs, such as shown in Figure 3, brought longer life and much higher lumens-per-watt specifications. So it has seemed to make sense to simply screw in CFLs where incandescent had been used before about 1995—again using large reflectors to collect and redirect the light to the target area. It all seemed so simple.

One could confirm in a few seconds that four 25-watt CFL's ( 100 watts ), with or without a reflector, could put more light onto a subject scene than a 100-watt incandescent with large flood reflector—but the CFLs would last 6-10 times longer.

With further tests we would observe the following-----.

A 100-watt regular A19 bulb with a large reflector (10 inch diameter) would put about triple the light onto a scene over one without any reflector (Figure 2) . But a CFL (Figure 3) with same reflector would typically show only about a 1.5:1 improvement. That might surprise many readers—who think a fluorescent Par 30 lamp “spotlight” can really be a spotlight.

But what really makes it almost impossible for the CFL to use any reflector effectively is the design of the CFL itself. At least in a regular incandescent lamp, the light comes off the tiny filament wire and can all be collected and redirected.

But in a coiled-glass-tube CFL like Figure 3, most of the emitted light comes off curved surfaces from various distances from one another, making it almost impossible for a single reflector to focus all the light rays. Furthermore, much of the emitted light is actually blocked by adjacent coiled-tube segments and is prevented from going forward.

So while a CFL is a more efficient creator of light than an incandescent, its size and shape prevent that efficient light from being used efficiently. That is why the published lumen-per-watt specs of the best CFLs are less than those for the newer types of very long, straight regular fluorescent tubes (such as 48 inch, 96 inch). A CFL simply does not have much compatibility with reflectors.

We see many fluorescent “floodlights” sold in hardware stores and home improvement stores. But we would find that they actually do not put much more light on an area than a regular cheap A-19 LED bulb. So these are very misleading products.

An incandescent or LED spot or floodlight can put much more light on an area than a lamp with no reflector. A 100 watt incandescent PAR lamp—which, inside, has a very carefully positioned filament wire--- *can put up to 10X more light on a small target than a regular bulb with no reflector !—because the filament and reflector can be precisely matched for excellent focusing.*

What this all says is that the ability of a reflector to collect and redirect light from light source is directly related to

1) The size of light source relative to the size of the reflector and

2) The exact position of that light source within the reflector.

In a halogen Par-type spot or flood light, we do not have a small bare filament in a much larger sealed bulb and then that bulb in a reflector-- but instead a short filament wire in a tiny glass "capsule". As shown in Figure 4, It is precisely positioned inside at the reflector's focal point and the reflector has a carefully designed parabolic shape. So the "Par" lamp is a better focusing method to start with.

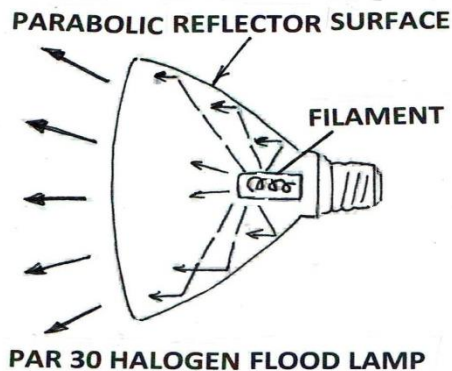

Figure 4

In a CFL, the preceding precision is impossible. So much of emitted light is actually wasted. Those who design reflectors for traditional incandescent lamps---auto headlights, flashlights, search lights, outdoor spotlights etc, know there are special mathematical rules for the necessary size ,shape and positioning of the lamp filament in order to a have efficient reflector focusing.

In a CFL there is no single small filament which can be at the reflector's focal point. The light comes from the long coiled tube---- makes it impossible to focus it properly without making the reflector enormous, typically over 36 inches in diameter. Even then, the light leaving any surface of the coiled tube at any one point can only be focused by a portion of the reflector and is being partly blocked from other coiled sections from reaching all parts of the reflector.

Conclusion about CFL's.—Even a very large high-quality reflector (at least 5 times the CFL diameter) can---at very best-----can only double the light on a target as compared to no reflector at all.

**HPS Reflectors** . HPS lamps are even more efficient (lumens per watt) than CFLs as light emitters. They have poor color accuracy but they are available very high wattages, and with low cost. Although their poor color accuracy make them unacceptable for professional photography and many other applications, their low cost and simplicity has given them a dominant global market share for horticultural lighting (i.e. grow lights) even as LED lights became available.

However, HPS lamps have many of the same problems as CFLs .In other words, just because the light seems to be creating so much light at cost low cost , does not mean all the light is getting to where we want it. See **Figure 5**

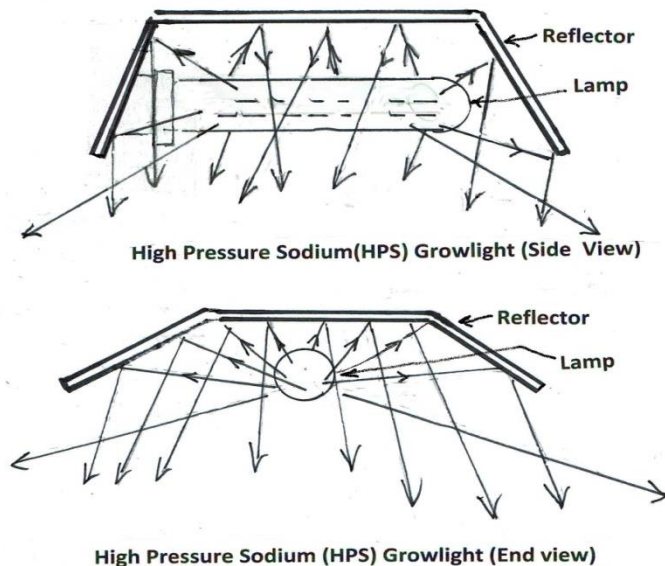

**Figure 5** Emission pattern of HPS Grow light

In a way similar to the CFL, light is emitted from a glass tube and goes in every direction-- almost 360-degree light emission. Only about 30% of the light actually goes in the direction we want. So we need a reflector to collect all that light and redirect to where we want.

We said earlier that there is a precise mathematical relationship between size and location of the light source and the shape of the reflector. In a precision incandescent or halogen reflector-as in a par lamp, the filament is very much smaller than the reflector. However, in the HPS unit used as grow-light the reflector is not large enough to have mathematical precision. It would have to be much greater size and weight—and far more expensive--- maybe 36 inches in diameter--- to perform well as an incandescent par lamp.

All this means that 100% of HPS grow-lights (all of them have built-in reflectors) do not focus the light very well. They do have good light uniformity across the grow bed. Unlike most LED grow light they do not have “hot spots ( i.e. excessive light) in the center and poor light around the sides. But they achieve that uniformity by wasting a very significant amount of light sent off to the sides.

HPS have many serious disadvantages and hidden costs but user do all kind so things to compensate for the disadvantages because of the low price. However new development, such as high-performance low-cost *MultiBEAM* technology, will make it more and more undesirable to use HPS.

### LED *MultiBEAM* Technology

Now let us look at light from an LED chip ( Figure 6 ) with a size typically about 040” X .040” — less the head of a pin. We can see the light ,even at the start, is emitted in the forward direction, That is ,in an incandescent filament CFL of HPS light source, where half the light is heading n the opposite direction in has t be reflected backwards even before it is focused in any way

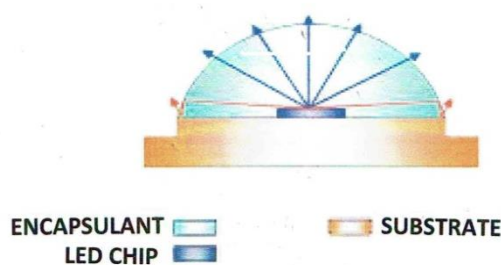
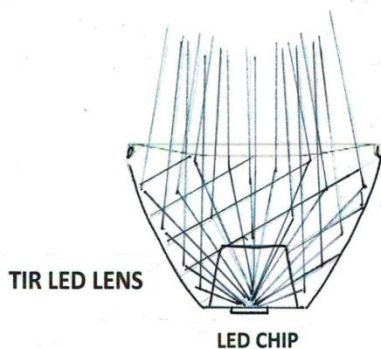

Figure 6 LED chip

Because mathematical rules for lenses and reflectors we mentioned earlier, a lens can be dramatically smaller. We can put over each chip a lens less .40” diameter and using what is called a Total Internal Reflection (TIR) technique. Figure 7 show a simplified view of how all the light coming off the LED chip is collected and redirected in an extremely complete, and efficient way--- very similar to how light is accurately collected in the “integrating sphere” we previously referenced.



**Figure 7** TIR LENS

A LED with TIR lens can increase the light intensity (i.e. the lux level on the target from 4X to 10X depending on the beam angle. A 60-90 degree beam angle, corresponding to what would be called a “flood” lamp, would exhibit at least triple the light the subject versus the same LED with no lens.

All of this means that an LED PAR lamp, with an array of its own integral “micro” TIR lenses, needs no additional external large reflector. This means an LED Par lamp, having 30-50% higher lumens per watt than any typical CFL of similar wattage to start becomes even more efficient when a proper lens is used

The result is that the *SuperFLOOD* and *MultiBEAM* LED PAR lamp, in addition to having 5 times as much life expectancy than a CFL, can put 3-4 times more light on an area as any CFL reflector combination.

### UNIFORMITY OF LIGHT DISTRIBUTION

In many special purpose lighting applications such as photo-studio lights, grow lights, athletic field or arena lighting, it is very important to have uniform distribution of the received light—that is, the actual light reaching areas where it is most wanted. For grow lights, uniformity means something very specific.

Uniformity= Average light across the grow bed divided by the Minimum. For example, if we has extreme brightness in the exact middle of the grow bed but very poor light at the sides and corners, that would be very poor uniformity. We would get very poor or unpredictable growth in various part of the grow bed. Poor light uniformity in a photographic scene also can create undesirable results.



For grow lights, uniformity needs to be better than 2:1 to be considered good

Almost all grow lights which have a dimension (Length X Width) much smaller than the area of the grow-bed, have poor uniformity—this especially is true for grow lights without any optics. It is very common to see grow lights with only 3:1 or 4: 1 uniformity. Figure 8 shows the side view of such a pattern---bright in the middle and a sharp drop-off at the sides

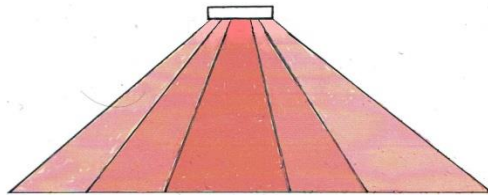

**Figure 8**

Many large growing facilities achieve good uniformity by having a large numbers of lights at substantial heights with inter-unit pacing so that adjacent light patterns overlap as in Figure 9

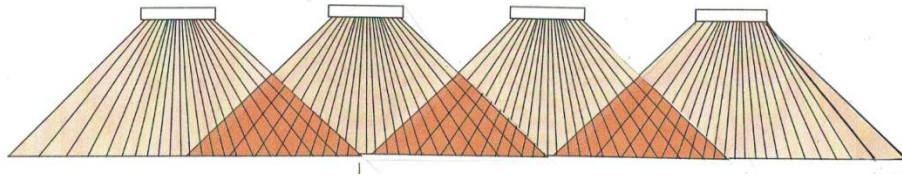

**Figure 9** Overlapping patterns with multiple LED light fixtures

But that is not always possible –and does not solve the problem for the user who needs to position a single fixture

Typically it is only possible to achieve best uniformity in a single light fixture by using a very large unit with an area about the same as the grow-bed itself. In other words if the grow bed is 48 inches X 48 inches then the lighting array needs to be the same. Figure 10 shows such a unit, (all using many “light bars”) made by some US and China firms. They are all heavy, expensive and expensive to ship. Also, they require assembly after shipment



**Figure 10** Large LED grow light array using many light bars—Typically 48 inch X 48 inch or one 1.0m X 1.0m

### **MultiBEAM Technology**

With the *MultiBEAM* method, there is a combination of a careful selection of lamp beam angle---wider than a typical LED spot or floodlight--- but narrow than the inherent 120 degree angle of an LED without optics. In this case we choose 60 degrees.

Next, instead of having all LED with the same beam angle aiming in the same direction—a standard method in 99% of all LED grow lights----and photographic lights as well)--- we break up the beam into four parts, each aimed an average of 35-40 degrees away from an adjacent lamp. The result is a beam of approximately 90 degrees which is more uniform than from a single light of the same 90 degree.

**Figures 11** shows a side view of that improved light pattern with **Figure 12** show how adjacent lamps are directed in slight different direction--- about 40 degrees apart) The result is a floodlight which magnifies the light sent to the grow bed but with much better uniformity than of a single standard floodlight or spotlight. The wasted light off to the side is minimized. The increase uniformity and reduction of wasted light has the same positive effect on grow-bed productivity as an additional 10-20% of grow-light watt

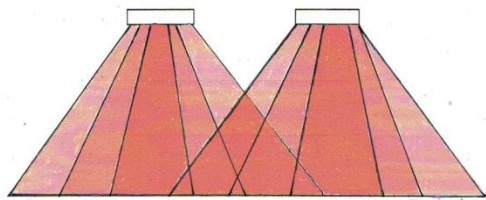

**Figure 11**

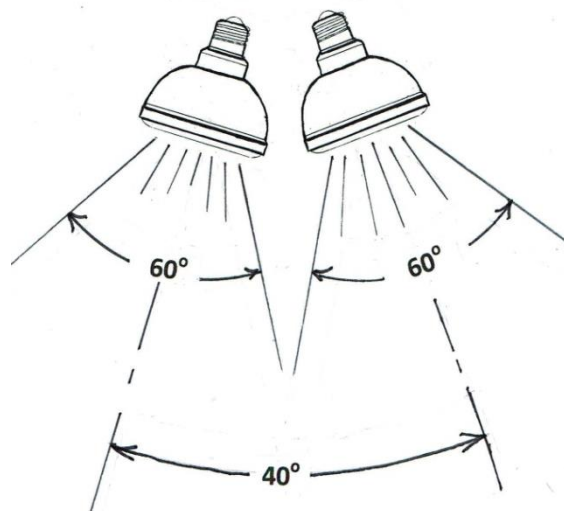

**Figure 12**

**Figure 13** shows a top view of the four overlapping light distribution patterns appearing on the surface. This is a simplified view but it does show how, instead of a single circle, very bright in the center and dim at edges, there are four circles with a center of lower brightness. The “center of this multi-beam center is now spread out to a wider area.

There is no need to get into a detailed technical analysis here but we can say that this overlap of four beams—which are already aiming in different directions—creates more uniformity over the entire area. Using lamps with a 60-degree beam angle to start with further helps the situation.

**Figure 13**

Overlapping beam patterns,  
Top view of the illuminated surface

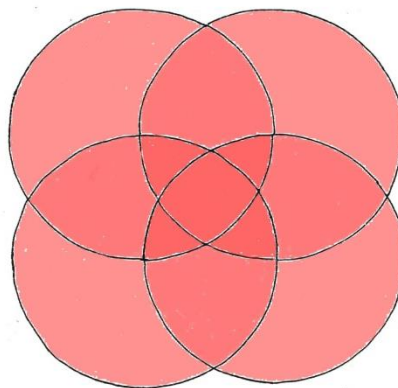

## COMPARISON OF CONTINUOUS-LIGHTING METHODS

Figure 10 compares various light sources, including the higher wattage methods used for photographic studio and grow-light applications. The comparison shows how much light will actually be present on a scene or grow-bed for a given amount of watts. (*Watts and lumens mean nothing if much of the light does not actually end up where we want it*) The most important observation is that a large reflector does not necessarily provide much benefit unless there is a proper mathematical relationship *between the size and shape of the reflector and the size, shape and position of the light source.*

In many LED lamps, instead of a single large light-emitter component, there are many tiny LEDs, each with its own small TIR lens. For any focusing one can use either a lens or a reflector. Lenses are typically more efficient and cost effective than reflector for individual small LED chips. But for single larger LED emitters, lenses would become large and far too expensive, so reflectors are typically used. For CFL or halogen light sources, above 10 watts lenses are out of the question, so large (5-12" reflectors are typically uses in photographic applications.

**FIGURE 14 Comparison of High-Wattage Lighting Methods**

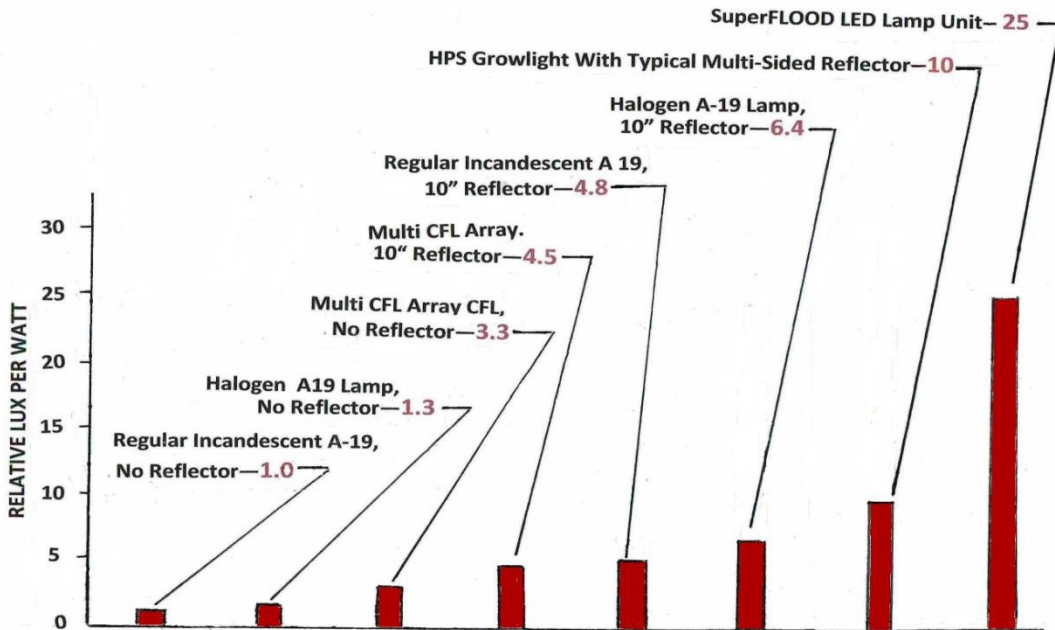

**1. What is the true meaning of LED watts?**

**1. First misleading way.** A search of the internet will show many high power grow lights at extremely low prices—such as less than e even .10 USD/per watt.—such 300 watt unit for only 30 USD

**But in 100% of these situations you will discover one of the following things==**

**They really mean it is as bright as an old inefficient 300 watt incandescent lamp but only uses 60 watts. But smart users know to always ask what e actually wall-plug power,--- the real wattage used. That is the real wattage rating. So not really .20/per watt. Really is .50 usd/per watt**

*Even though nobody uses incandescent lamps for commercial light, China export companies still continue to promote in this very misleading way*

**2. Next misleading way.** *Company says it is 500 watt grow-light because they use 500 watts of LEDs. But meaningless. Many companies use 2 watt led solute maximum wattage rating but only operate at 0.5 watt. That is very common*

*All good LED engineers know maximum wattage rating only means that unit will blow up and fail above that max rating. But performance starts to be poor at much lower wattage. So all major reputable LED companies specify best lumens per watts at much lower wattage such has  $\frac{1}{4}$  as much wattage.*

*So a grow light cannot be rated just by Max wattage of the chip used. That is meaningless and just trying to fool customers. Top global grow-light companies Like Philips., GE, Osram etc—never do that. Again--- **the only true wattage rating is the wattage which can be measured at the AC outlet.** Many China grow-light companies purposely do not give this proper information on the data sheet.*